



# MAXIMIZER

## Batch high-efficiency regrader

MAXIMIZER is the new batch high-efficiency regrader designed to dry, decontaminate and regrade polymers with low consumption, while also ensuring an effective storage for the material. Maxymizer aims to maximize the return on investment on recycled polymers

### OPERATING PRINCIPLE

The material conveyed in a typical loader is discharged inside a reactor, within which the simultaneous action of IR lamps to heat the material, a vacuum pump to suck the gases and a mixing shaft ensures an homogeneous process of both drying, decontamination and regrading of the polymer, which is afterwards stored in a special tank that preserves its conditions and quality for long time.



### MAIN FEATURES

#### HIGH EFFICIENCY

Taking advantage of the heating principle made by IR lamps in a vacuum a lot of heat is granted to the polymer in a very small span, shortening the process time by a lot; the reactor is designed to also minimize the heat dispersion, avoiding almost any kind of energy waste.

#### TRIPLE FUNCTION

Maxymizer can be set on three different temperature thresholds, performing three different functions on demand: at 180 °C the material is dried by extracting the water vapour, at 200 °C the contamination of now volatile compounds such as acetaldehyde is removed, and at 220 °C the material undergoes Solid State Polycondensation (SSP) which improves its quality via intrinsic viscosity (IV).

#### LONG-TERM STORAGE

Maxymizer employs a high-insulation storage tank designed to preserve the high temperature and low humidity conditions of the material achieved in the reactor, serving both as a reliable storage and as an extension of the thermal treatment

#### DIFFERENT SIZES

Maxymizer is designed in various sizes, from the 150 L typical of laboratories to higher volumes more easily found in production lines.

#### COMPACT DESIGN

The design aims to optimize the space by clustering together the loader, the reactor and the tank in a single structure in order to minimize the vertical dimension.

REGRADER PROCESS

ABS PROCESS

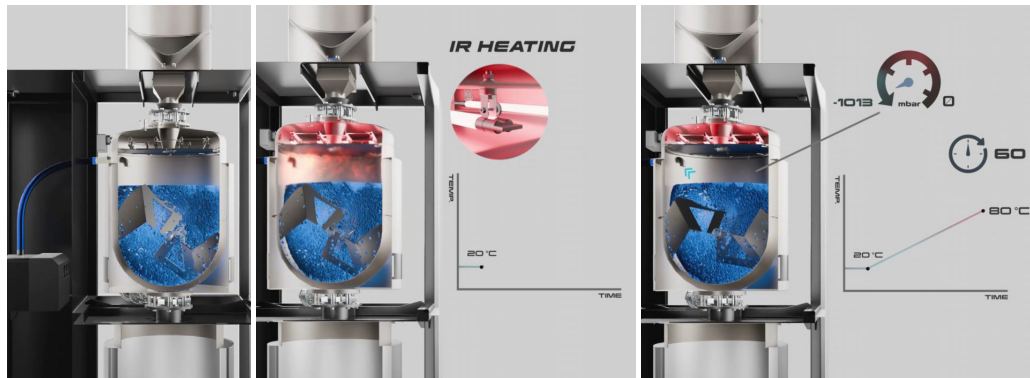

PET PROCESS



TECHNICAL DATA

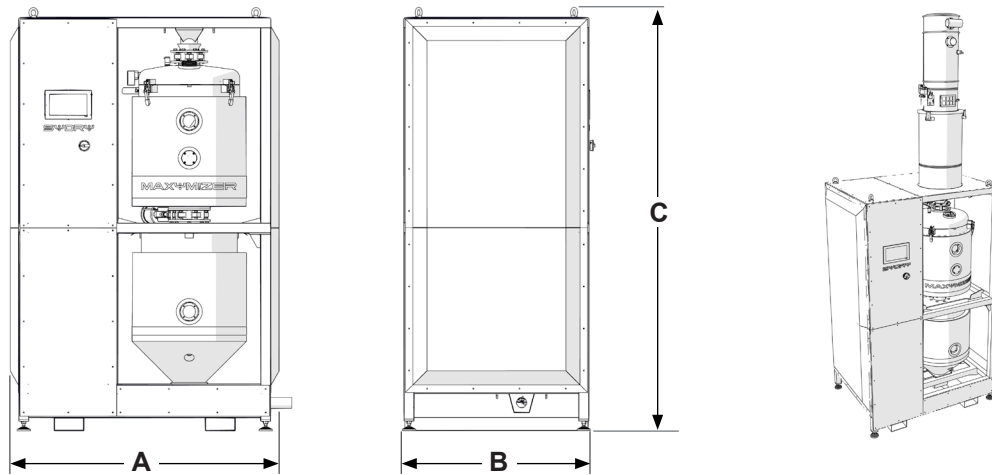

Model	Maxyimizer 60	Maxyimizer 125	Maxyimizer 250	Maxyimizer 500
Output (Kg/h)	60	125	250	500
Preheating hopper volume (Litres)	100	200	400	800
Material in the preheater (Kg)	70	140	280	560
Reactor volume (Litres)	60	125	250	500
Material being processed in the reactor (Kg)	42	87,5	175	350
Buffer hopper volume (Litres)	60	15	250	500
Maximum temperature (°C)	230			
IR dehumidification power (kW)	4,5	9	18	35
IR supercleaning power (kW)	6,5	13,5	26,5	52,5
Dimension A (mm)	1400*	1600*	2100*	2500*
Dimension B (mm)	1250*	1150*	1300*	2500*
Dimension C (mm)	2650*	2650*	2850*	3250*

\* Dimensions and weights to be defined with Sydry's technical department at a preliminary stage.